

DEM Design. Engineering. Manufacture.

“Supporting the Steel Framing Industry”

11 Storey Residential Solution in Light Gauge Steel



Tel. +44 1423 535650

Tel. +44 1423888291

Tel. +44 1423500211

“Supporting the Steel Framing Industry”

DEM is the combination of the knowledge of three well established companies that are working together to make the transition to using Light Gauge Steel Construction easier to handle.

Hill Cannon (UK) Limited

Hill Cannon (UK) Limited are a leading Civil and Structural Engineering Consultancy which have been in practice for over forty years. They have a dedicated Modern Methods Department which is at the cutting edge of Light Steel Framing design, with over ten years experience in the area, as well as other MMC methods. The Modern Methods Department, with the SCI, is already developing designs to the upcoming Eurocodes (EC3, due out in March 2010) to gain the most competitive advantage they can for you, our client.

Howick Ltd.

Howick have been building rollforming equipment for over 30 Years. Their focused Framing Machines are designed to quickly produce accurate load bearing frames that allow the production of multi storey structures.

Howick offer customised tooling to suit your specific needs where required.

Vertex

Vertex is the leading building design software company that allows full design of all components from the foundation to the walls, floors and roof design. Design is made easy with various automated features as well as a library of building components that allow the designer a high degree of flexibility to take both the exterior and interior to a fully finished state including furnishings. Vertex then has an automated and custom link to the Howick Rollforming machine to turn accurate building design into accurate production.



What can DEM do for you?

We don't propose we do all the work for you but we do make three of the largest components of your business easier. By offering our knowledge in each of our specialist areas.

The three main Questions we answer are:

How do I take those initial plans from concept to production ready designs?

How do I make sure the designs meet the required standards and codes?

How do I produce the framing components and what equipment do I need?

“Supporting the Steel Framing Industry”

DEM Package 1 (Low Rise)

- 2 Seats Vertex BD FRAMER.
- Vertex Training (3 days), Technical Support and 1st years maintenance.*
- SCI Technical manual.
- Standard Details Documentation.
- 75 Hours of Engineering consultancy from Hill Cannon (UK) LLP including 1 UK Site visit / attendance of a design meeting.
- Indicative design cost estimation documents.
- Howick 89mm or 100mm H500 Framing machine and Decoiler installed and operator training provided.
- 2 additional visits to your site by a Howick technician for additional training and maintenance.**

DEM Package 2 (Medium Rise)

- 2 Seats Vertex BD Pro.
- Vertex Training (4 Days), Technical Support and 1st years maintenance.*
- SCI Technical manual.
- Standard Details Documentation.
- Indicative design cost estimation documents.
- 110 Hours of Engineering consultancy from Hill Cannon (UK) LLP including 1 European Site visit / attendance of a design meeting.
- Howick 89mm or 100mm H500 Framing Machine and Decoiler installed and operator training provided.
- Howick 150mm H500 Framing Machine and Decoiler installed and operator training provided.
- 2 additional visits to your site by a Howick technician for additional training and maintenance.**

DEM Package 3 (Medium Rise)

- 2 Seats Vertex BD Pro Including G4 add on.
- Vertex Training (4 + 2 Days), Technical Support and 1st years maintenance.*
- SCI Technical manual including Floor Joist.
- Standard Details Documentation.
- Indicative design cost estimation documents.
- 110 Hours of Engineering consultancy from Hill Cannon (UK) LLP including 2 European Site visits / attendance of design meetings.
- Howick 70 or 150mm H500 Framing machine and Decoiler installed and operator training provided.
- Howick 89mm or 100mm H500 Framing machine and Decoiler installed and operator training provided.
- Howick 250mm H600 Floor Cassette Machine and Decoiler installed and operator training provided.
- 2 additional visits to your site by a Howick technician for additional training and maintenance.**

Additional Options

- Vertex G4 package.
- Contract vertex design service.
- Additional Engineering Consultancy hours from Hill Cannon (UK) LLP.
- Howick maintenance contract.
- Additional Howick Machine tooling customisation.

*Training at Vertex's offices, training available onsite with Travel Costs additional.

**Travel and Parts additional.

11-Storey Light Steel Frame Building

A brief study has been carried out to determine the max possible floor span for an eleven-storey residential light steel frame building based upon typical domestic loadings in the UK. Analysis was carried out using 75,100 and 150 section profiles. The maximum allowable floor span is estimated based on the stud's critical capacity at ground floor. The studs are assumed to be space at 200c/c (400c/c back to back sections) at ground level. Detailed design will give stud centres at the intermediate floors, but it can be assumed that 600mm centres will suffice at eleventh floor.

The max axial load and moment acting on the studs is calculated. Hence the maximum floor span can be determined at each storey.

Three different section profiles are used for this exercise that consists of 75x41.3x1.6, 100x41.3x1.6 and 150x45x1.6. Details of the profiles are included on the next page.

Wall panels are assumed to be board/rendered finish for design. Design assumes party walls (twin skin construction) between adjacent apartments/accommodation. It should be noted that masonry cannot be self supporting over a height approximating three storeys, so should be avoided above the third floor in a project such as this.

The floor will be Lewis decking with 50 mm Gylon concrete screed. Floor to floor based upon 2.85 metres. Domestic Imposed / Live loading of 1.5kN/m^2 (150Kg/m^2) is assumed for design with a suitable self weight.

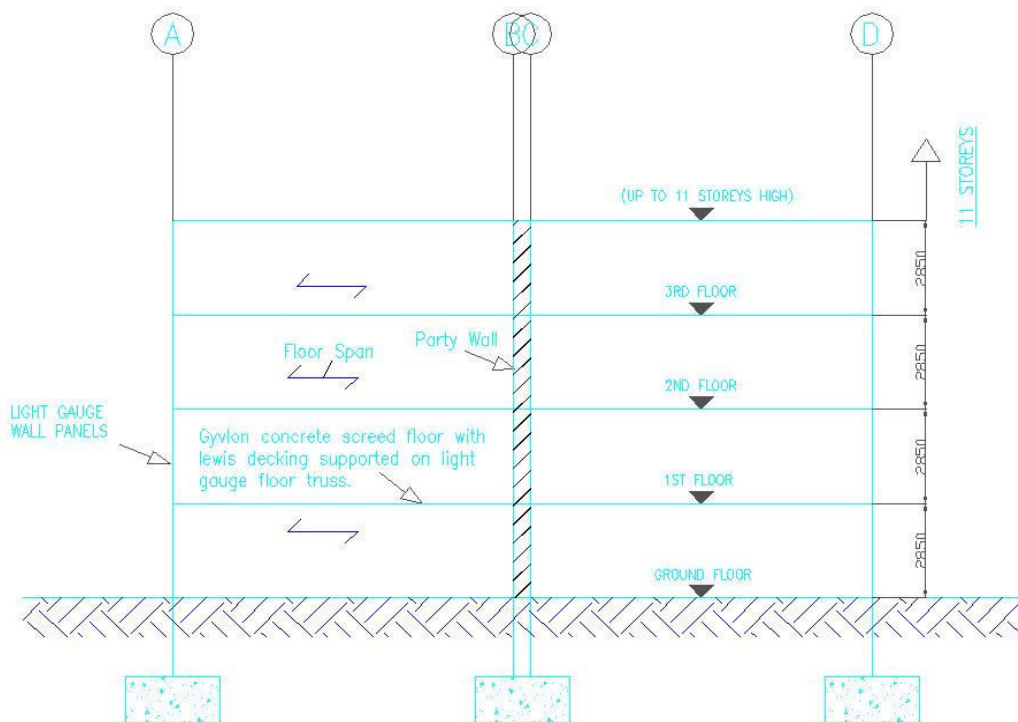

Typical Light Steel Frame Layout

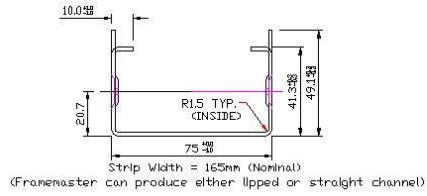

75mm Section

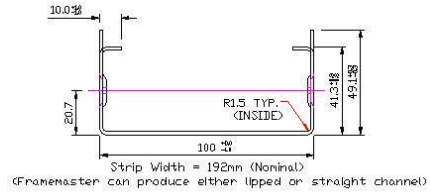

100mm Section

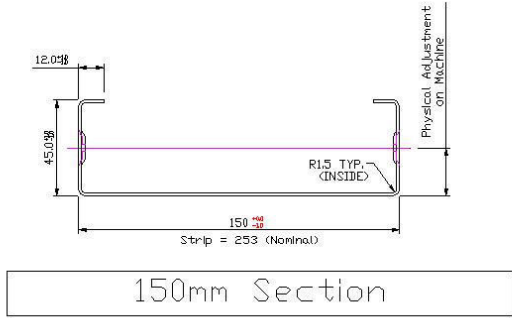

150mm Section

Typical Section Profiles

TYPICAL MAXIMUM FLOOR SPAN FOR WALL PANEL SECTIONS SPACED AT 200mm c/c (400mm/c BACK TO BACK) SECTIONS.

<u>TYPICAL WALL SECTIONS</u>	<u>MAX FLOOR SPAN</u>
75x41.3x1.6 @200mmc/c	6.3 metres
100x41.3x1.6 @200mmc/c	6.9 metres
150x45x1.6 @200mmc/c	8.1 metres